

# HS 3540



# Crystalyte europe

## Technische fiche

Motor type	Borsteloos direct aangedreven
Vermogen bereik	250 - 2000 Watt
Voltage bereik	24 - 48 Volt
Maximale stroom	45 Amp
RPM / V	10
Koppel	40 - 80 Nm
Efficiency	86%
Gewicht	6,5 kg
Inbouwbreedte	135 mm
Schijfrem montage	Ja
Freewheel montage	Ja
Voor- of achterwiel	Achterwiel
Controller type	Sensorloze en sensed controllers

Magneet breedte	35 mm
Polen	23 paar
Hall sensoren	3 x Honeywell
Lagers	NSK industrieel
Waterkeringen	Ja
Motor fase stekker	3 x Anderson PP45
Hall sensor stekker	Mini XLR 5 pin

### OOK BESPAAKT LEVERBAAR

Spaken	SAPIM 12G RVS (dikte = 2,6 mm)
Velg	EXAL EX19 (24" - 29") / XL25 (20")
Velgmaten	20", 24", 26", 28" en 29er



HS 3540

**BESTEL ONLINE**  
[www.crystalyte-europe.com](http://www.crystalyte-europe.com)



## Makes you want to drive electric

e-dr bvba • Hemelrijken 3a • 2890 Sint-Amands • België • +32 (0)52 555 840 • info@crystalyte-europe.com

## Afmetingen

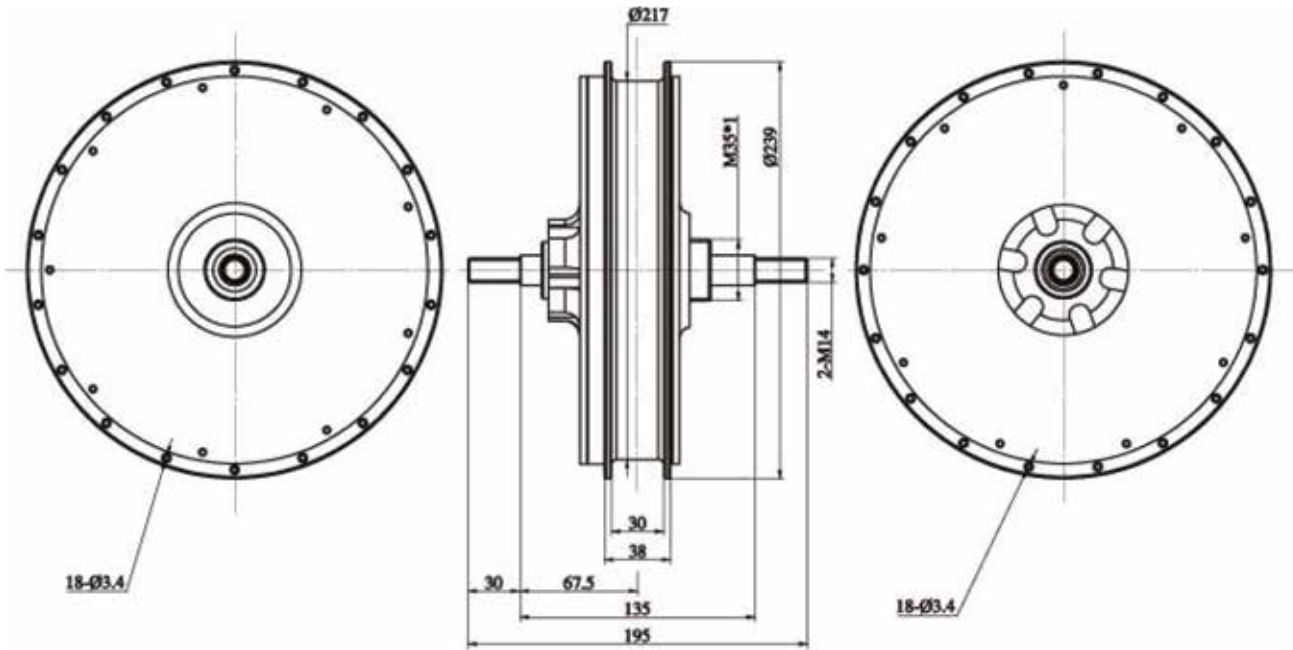

## Testbankresultaten\*

Omschrijving	U (V)	I (A)	P1 (W)	M (N.m)	N (rpm)	P2 (W)	Eff (%)
<b>Unload</b>	35,90	1,543	55,41	0,07	350,8	2,57	4,6
<b>Max-Eff</b>	34,87	14,29	498,5	13,42	306,3	430,3	86,3
<b>Max P-out</b>	34,87	26,02	907,6	26,53	271,9	755,2	83,2
<b>Max-Torque</b>	34,99	24,92	872,1	60,09	22,6	142,1	16,3
<b>End</b>	34,99	24,93	872,1	60,09	22,6	142,1	16,3

\* Gemeten met 36V en 25 Amp controller

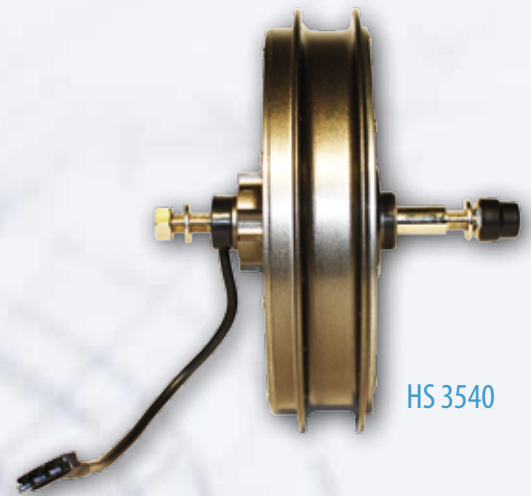

HS 3540

## Snelheidstabel

