

# HS 2440



VOORWIEL MONTAGE

# Crystalyte

europa

## Technische fiche

Motor type	Borsteloos direct aangedreven
Vermogen bereik	250 - 1500 Watt
Voltage bereik	24 - 48 Volt
Maximale stroom	40 Amp
RPM / V	9,5
Koppel	40 - 65 Nm
Efficiency	84%
Gewicht	5,5 kg
Inbouwbreedte	100 mm
Schijfrem montage	Ja
Tandwiel	nvt
Voor- of achterwiel	Voorwiel
Controller type	Sensorloze controllers

Magneet breedte	24 mm
Polen	23 paar
Hall sensoren	Nee
Lagers	NSK industrieel
Waterkeringen	Ja
Motor fase stekker	3 x Anderson PP45
Hall sensor stekker	nvt

### OOK BESPAAKT LEVERBAAR

Spaken	SAPIM 125G RVS (dikte = 2,6 mm)
Velg	EXAL EX19 (24" - 29") / XL25 (20")
Velgmaten	20", 24", 26", 28" en 29er
Kleur	Zilver of zwart



BESPAAKT  
LEVERBAAR



HS 2440

BESTEL ONLINE  
[www.crystalyte-europe.com](http://www.crystalyte-europe.com)



## Makes you want to drive electric

e-dr bvba • Hemelrijken 3a • 2890 Sint-Amands • België • +32 (0)52 555 840 • info@crystalyte-europe.com

## Afmetingen

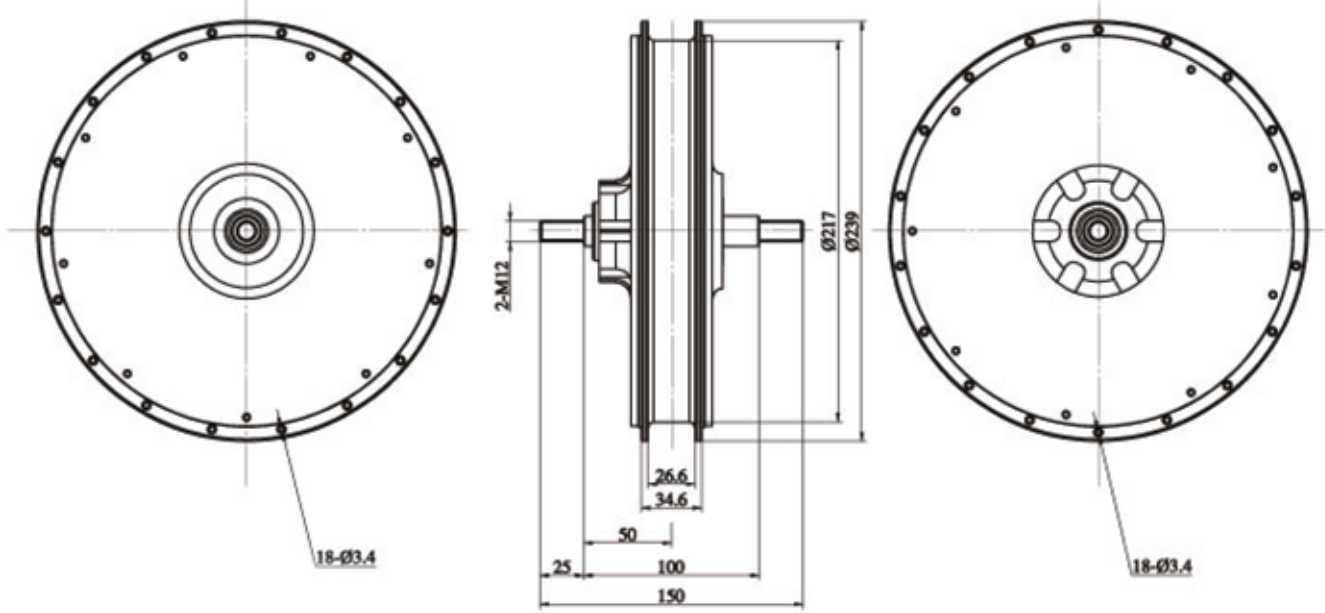

## Testbankresultaten

Omschrijving	U (V)	I (A)	P1 (W)	M (N.m)	N (rpm)	P2 (W)	Eff (%)
<b>Unload</b>	35,89	1,030	37,00	0,03	341,5	1,07	2,8
<b>Max-Eff</b>	35,48	11,90	422,5	11,77	290,1	357,4	84,6
<b>Max P-out</b>	35,01	25,21	882,9	26,87	233,8	657,7	74,4
<b>Max-Torque</b>	35,01	25,94	908,4	47,56	21,9	109,0	12,0
<b>End</b>	35,01	25,94	908,4	47,56	21,9	109,0	12,0



HS 2440 - bespaakt

## Snelheidstabel

